

NOAA-PMEL's T-FLEX system for PIRATA and RAMA



Christian Meinig,
Pat Mclain, Paul Freitag,
Noah Lawrence-Slavas, Tim Smith, & many more

Pacific Marine Environmental Lab
Seattle, WA

Topics:

- Background
- System Description
- Intercomparison
- Next Steps
- Future

RAMA/PIRATA Moorings

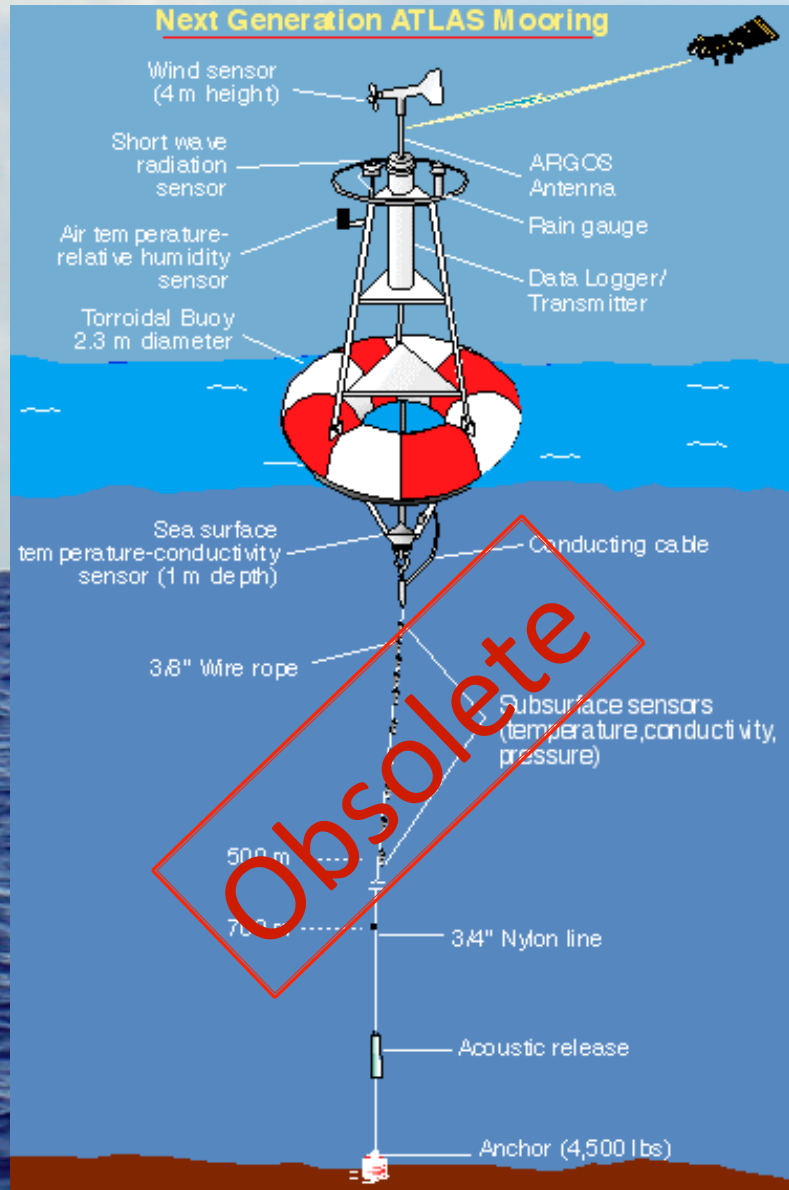

Obsolete

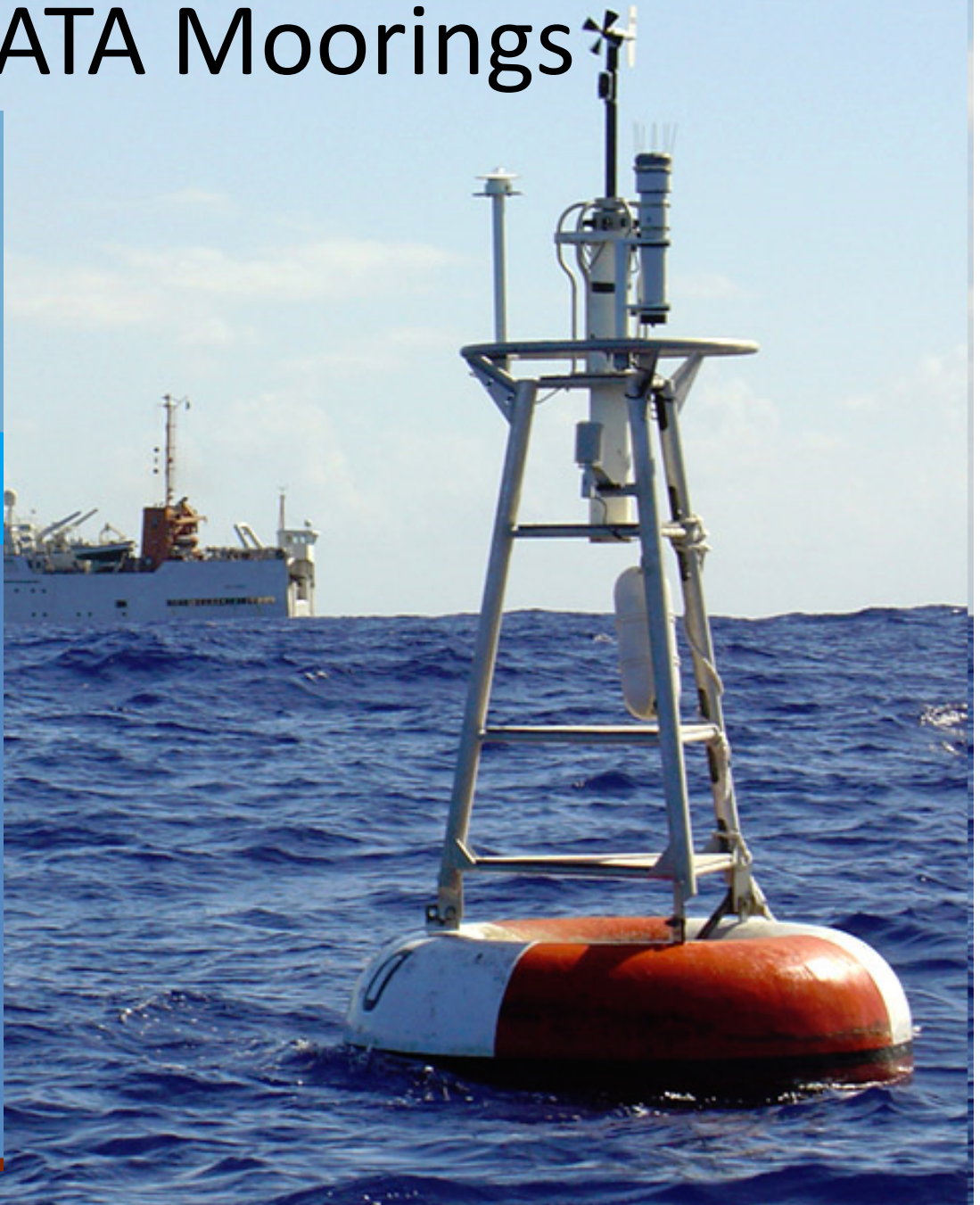

Project Requirements

- Address Obsolescence w/proven core technology
- Same data quality standards (per Climate Principles)
- Cost containment
 - Use ATLAS components when practical
- Whole Life-Cycle Engineering
- Flexible Electronics Architecture
- Vandalism considerations
 - More RT data
 - Hardware
- Extended Endurance
 - ~18 months

FLEX Background

*field proven, developed
for high latitudes*

- Flexible electronics/
software

*.....robust & adaptable,
but not
'plug and work'*



ATLAS-T-FLEX Data comparison

Report completed in July 2010

Includes:

ATLAS & FLEX high resolution data along with
a Vaisala WXT-520

		Std. Dev.						Regression Slope	Regression Offset	R ²
		Mean Diff.	Diff.	RMS Diff.	Min. Diff.	Max. Diff.	Mode Diff.			
AT	ATLAS - Flex Rotronic (Sep 2008 - Apr 2009)	-0.055	0.093	0.108	-1.51	1.33	-0.1	1.002973	0.00	0.9995
	ATLAS - Flex Vaisala (Sep 2008 - Apr 2009)	-0.029	0.167	0.169	-2.47	1.36	-0.1	0.994419	0.13	0.9984
	Flex Rotronic - Flex Vaisala (Sep 2008 - Sep 2009)	0.002	0.174	0.147	-1.4	1.5	0.0	0.998098	0.04	0.9986
RH	ATLAS - Flex Rotronic (Sep 2008 - Apr 2009)	0.047	2.163	2.163	-8.14	12.30	-0.6	1.066534	-5.00	0.9658
	ATLAS - Flex Vaisala (Sep 2008 - Apr 2009)	5.752	3.400	6.681	-8.89	26.33	4.5	1.099952	-13.19	0.9233
	Flex Rotronic - Flex Vaisala (Sep 2008 - Sep 2009)	7.072	2.567	7.523	-6.2	19.6	4.8	0.928033	-1.31	0.9611
BP	Flex Paros - Flex Vaisala (Sep 2008 - Sep 2009)	0.040	0.207	0.211	-2.6	1.0	-0.1	0.99278	7.28	0.9987

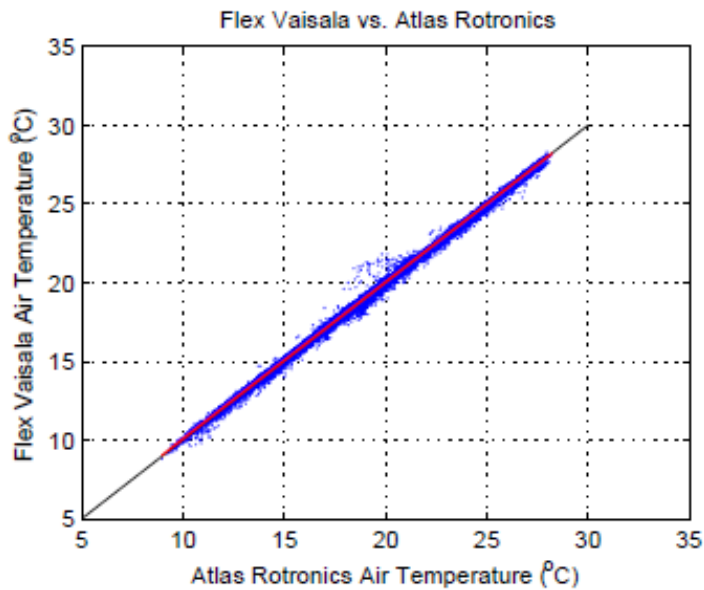
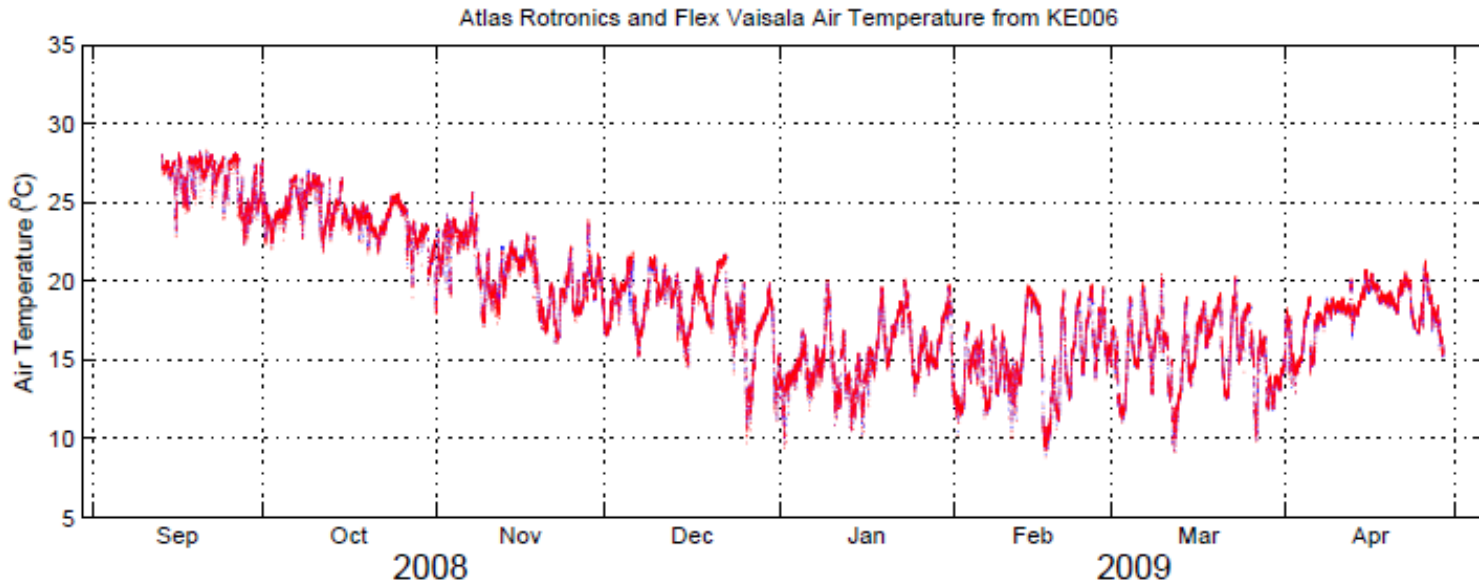

$$y = 0.994419x + 0.133923$$

slope error = 0.001318

y-intercept error = 0.025322

$$R^2 = 0.99843$$

Figure 3

ATLAS-Gill Vs. Flex-Gill, Uncorrected Winds

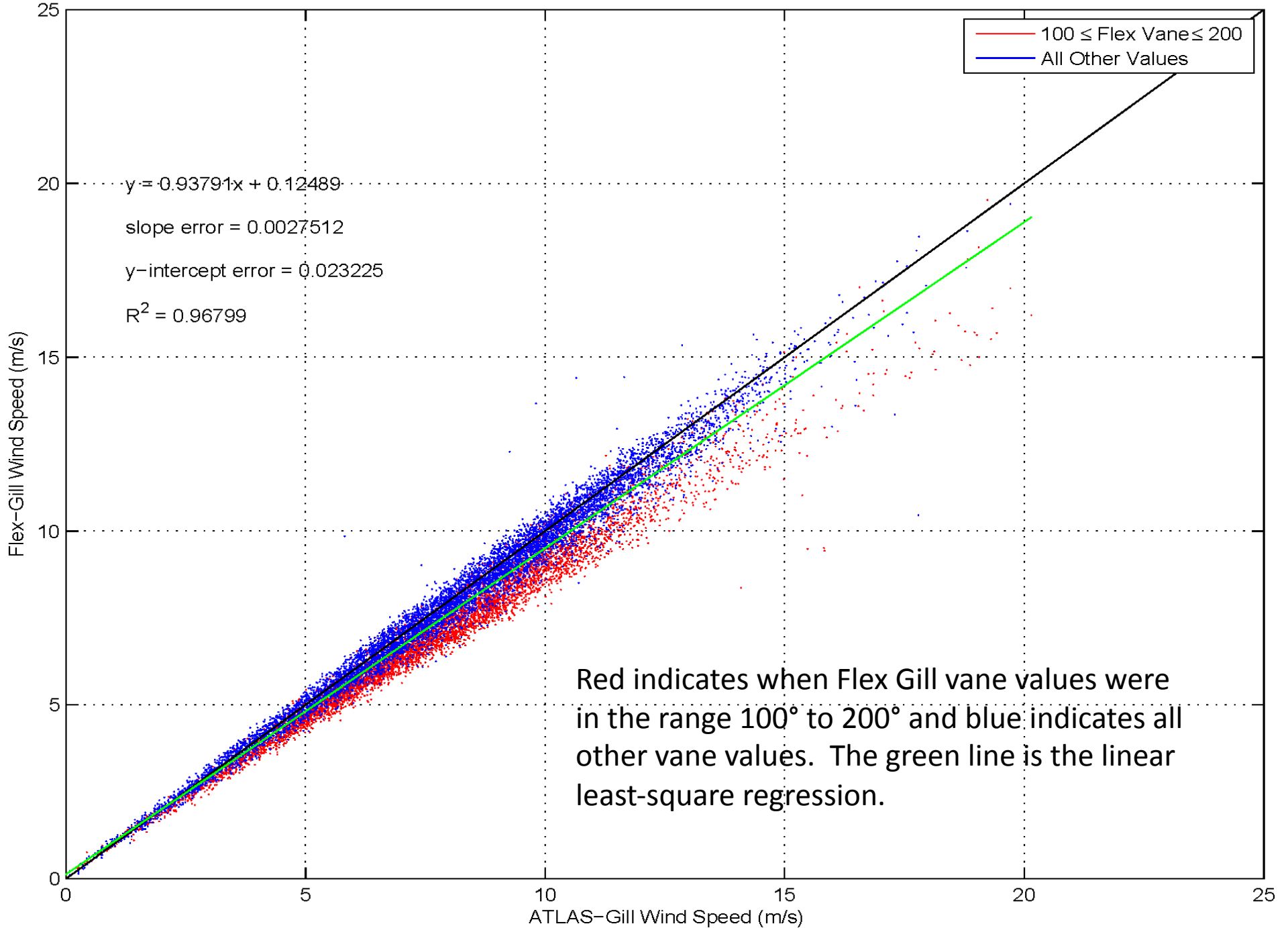

8.11076
7.29968
6.10964

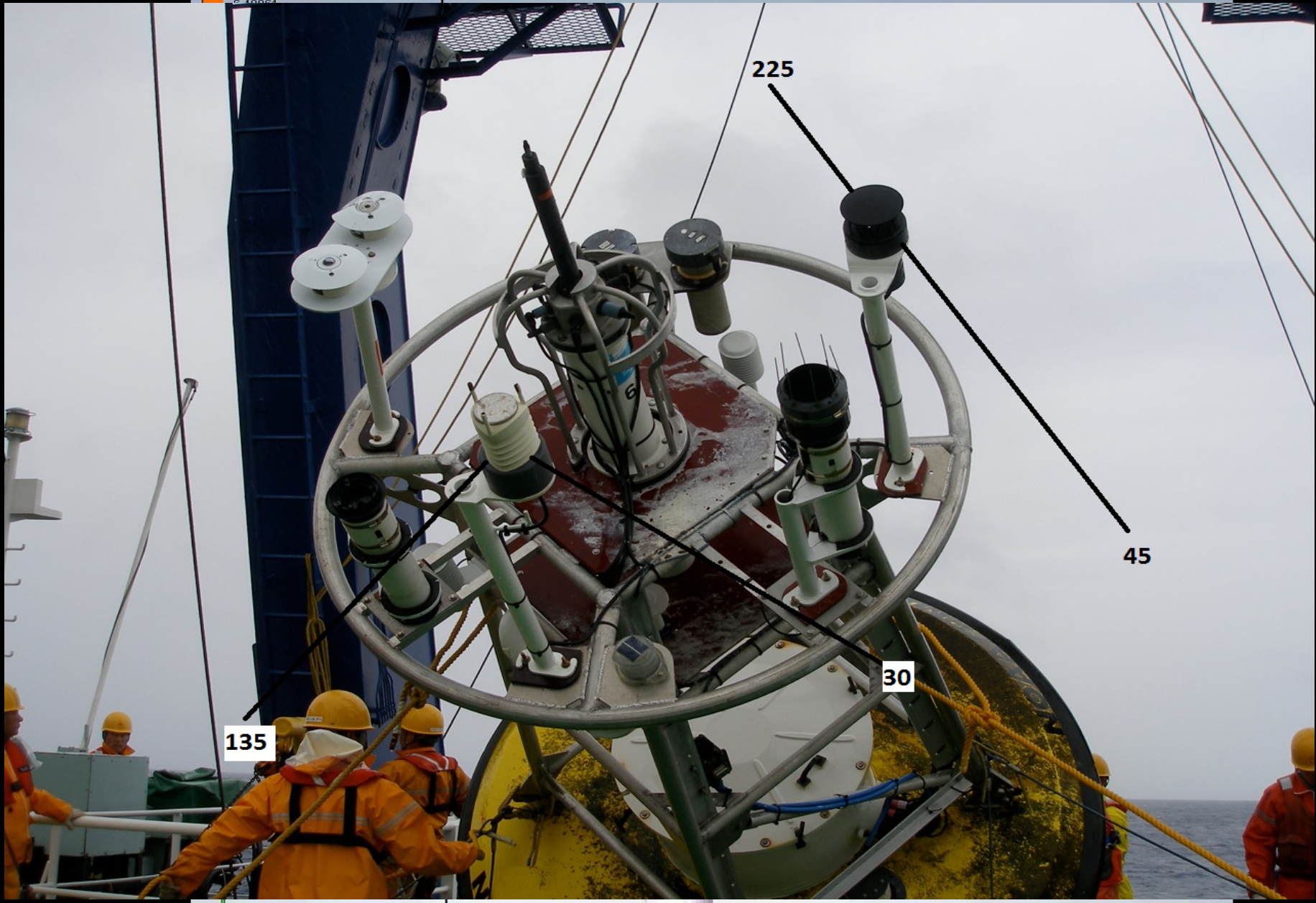

225

45

30

135



T-FLEX Surface Instrumentation

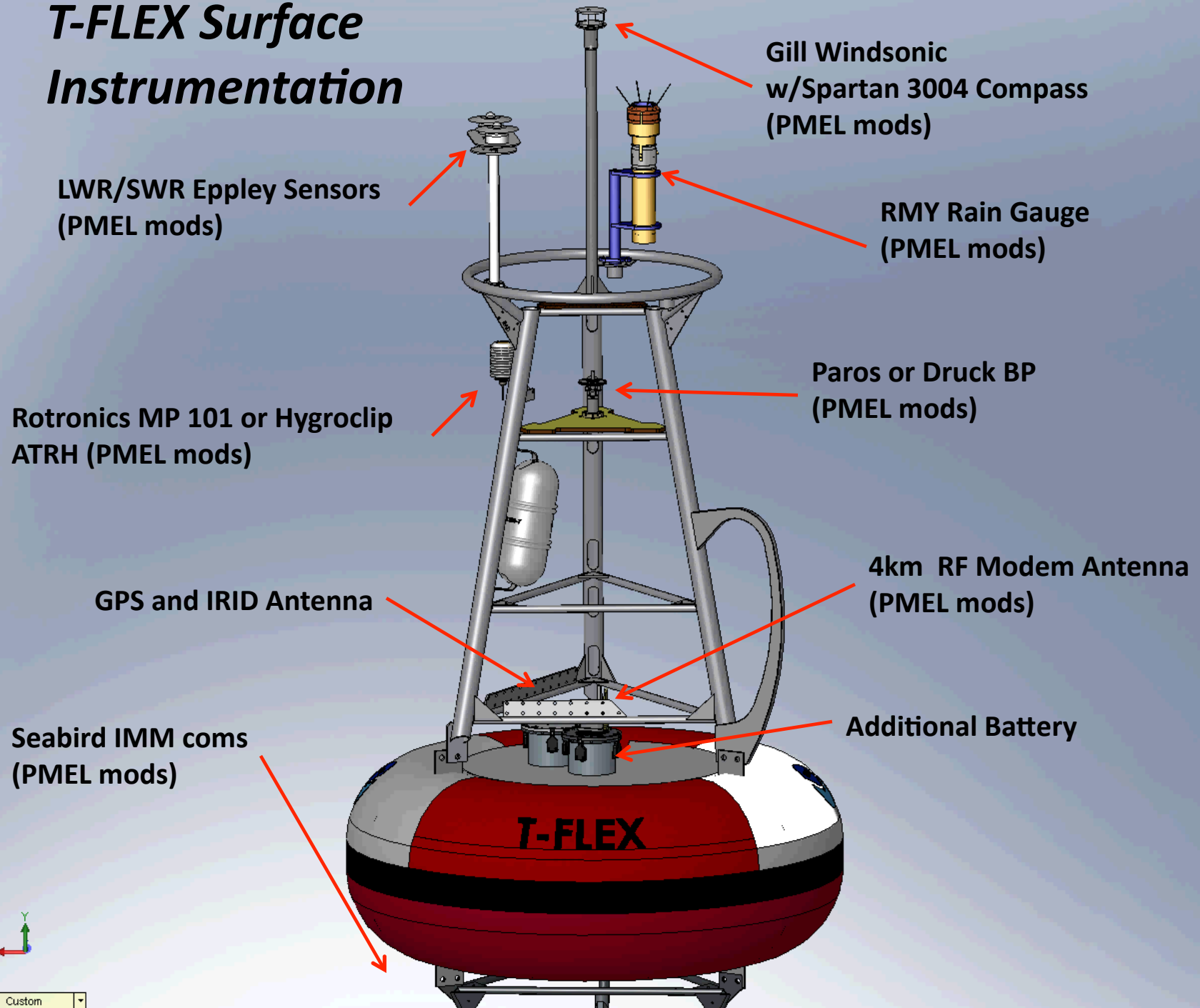

Subsurface Instruments

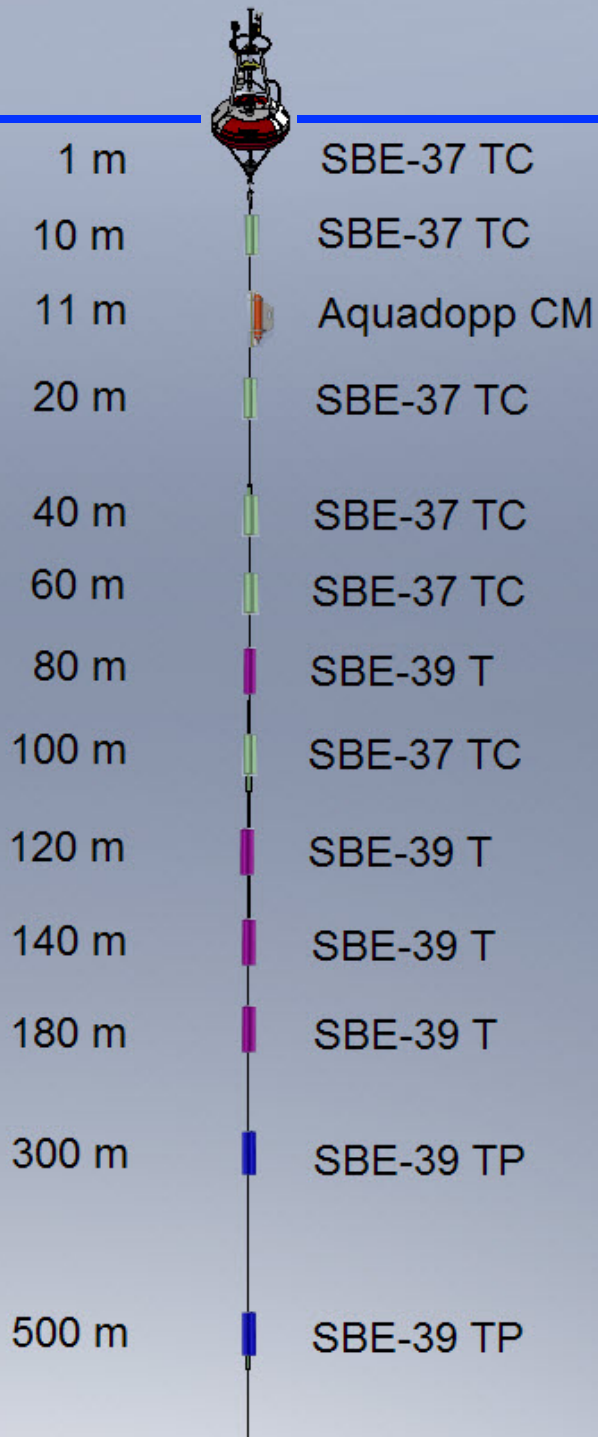

**Commercial
No PMEL mods
needed**

Electronics Tube

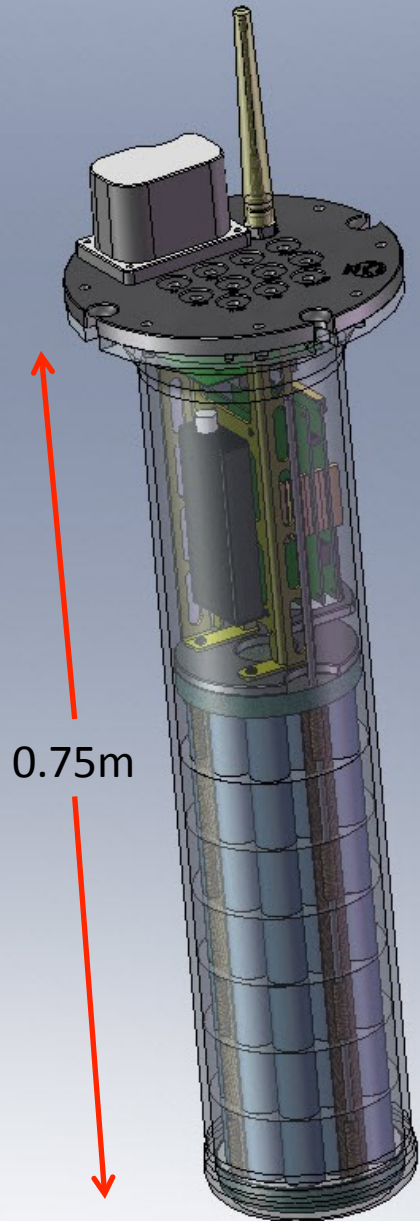

IRID/GPS
Antennae



RF Modem Antenna



Connection Faceplate



Ribbon Cable
Junction



T-FLEX Board Stack



IRIDIUM



Electronics Chassis



7x14 Battery Stack

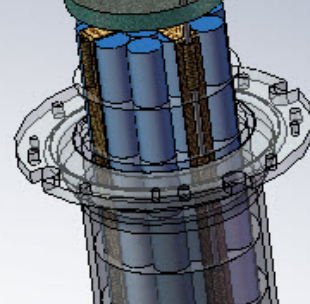

Example: Ruggedized Wind Sensor

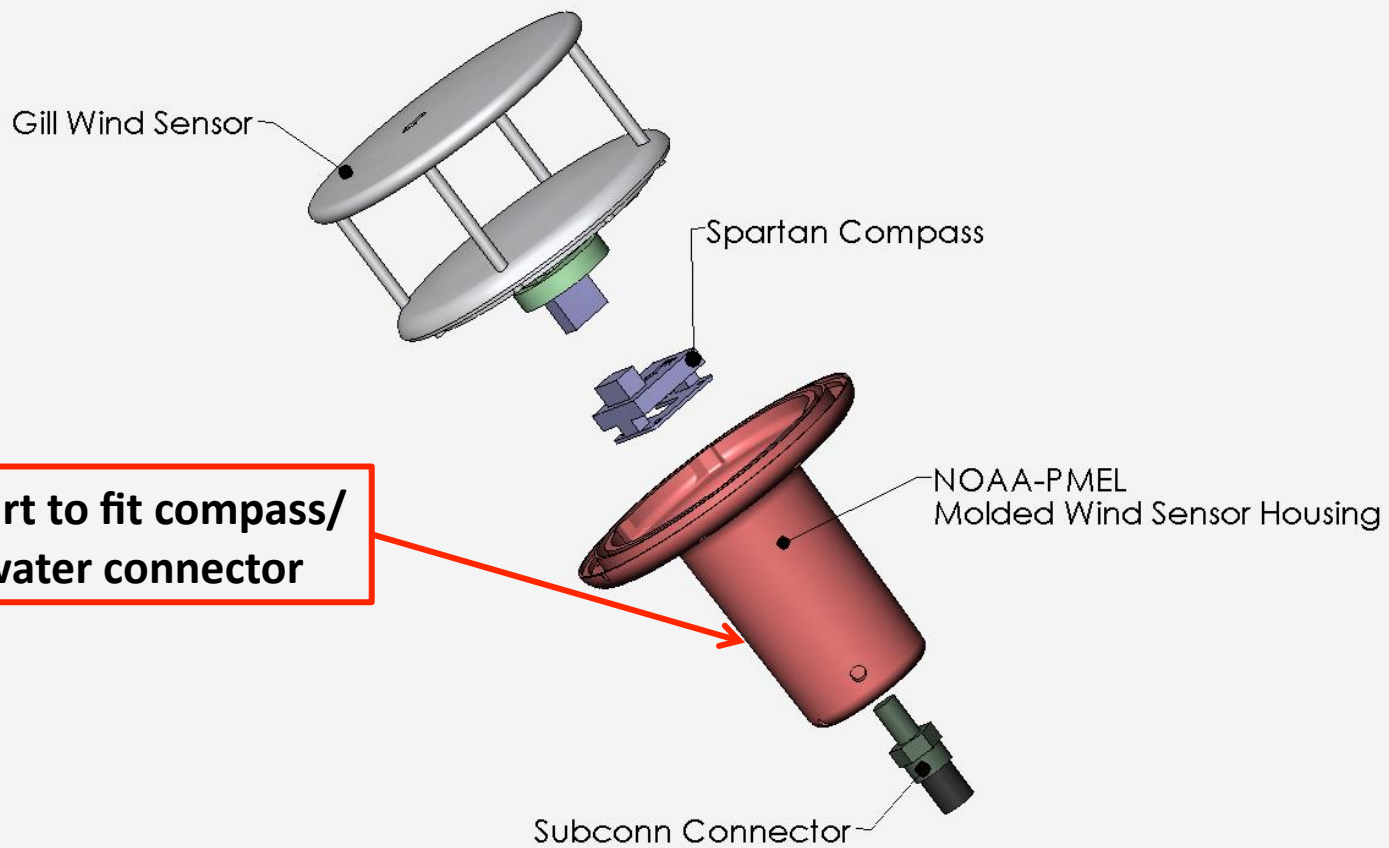

PMEL Gil molded part



Example: *AT/RH Sensor*

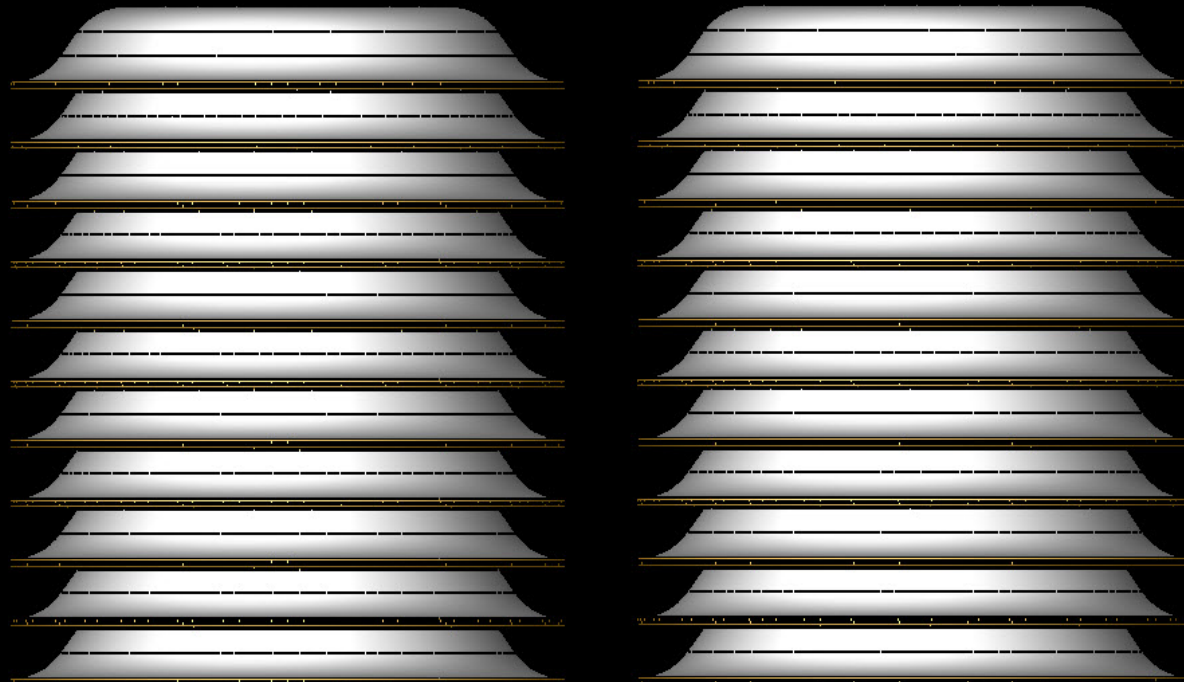

Rotronics MP-101

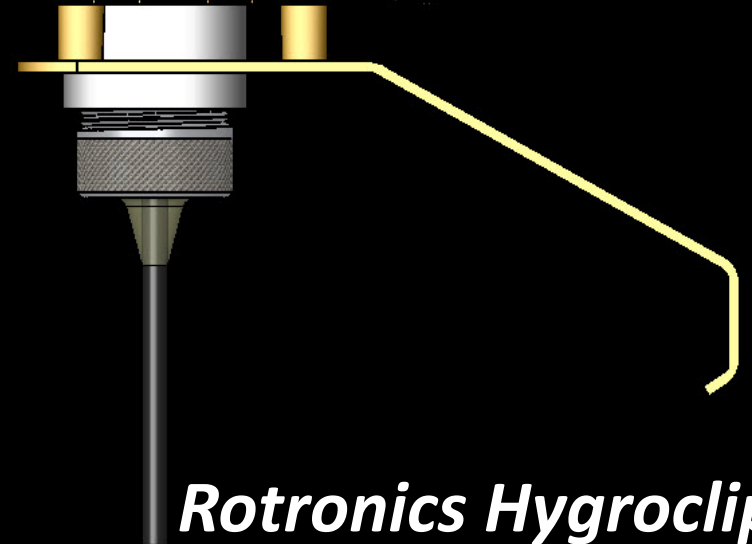

Rotronics Hygroclip

AT/RH Sensor

**Rotronics
MP-101**

**Rotronics
Hygroclip**

115mm

20mm

Thermal mass reduction ~60%
Area reduction ~80%

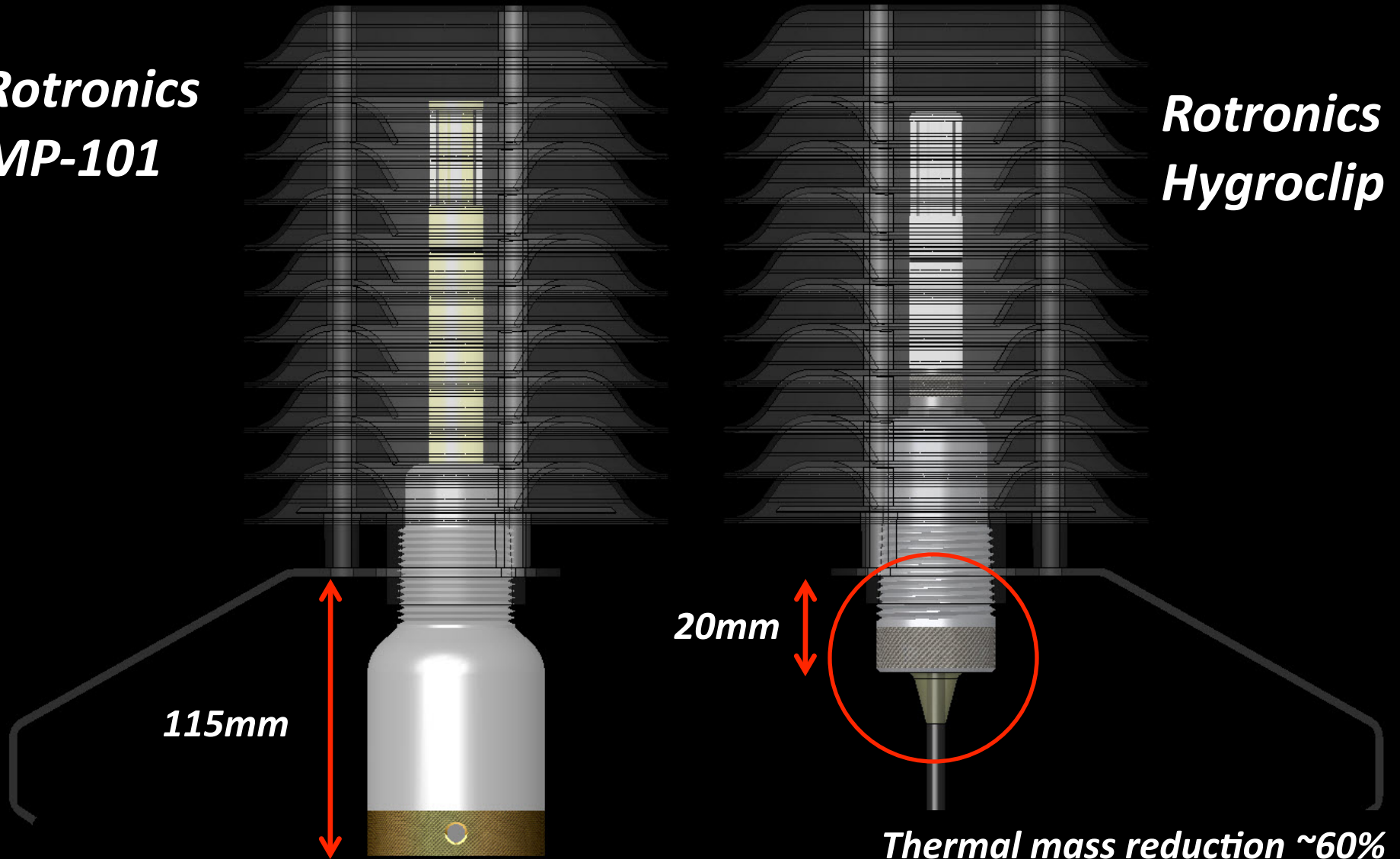

Antitheft Toggles

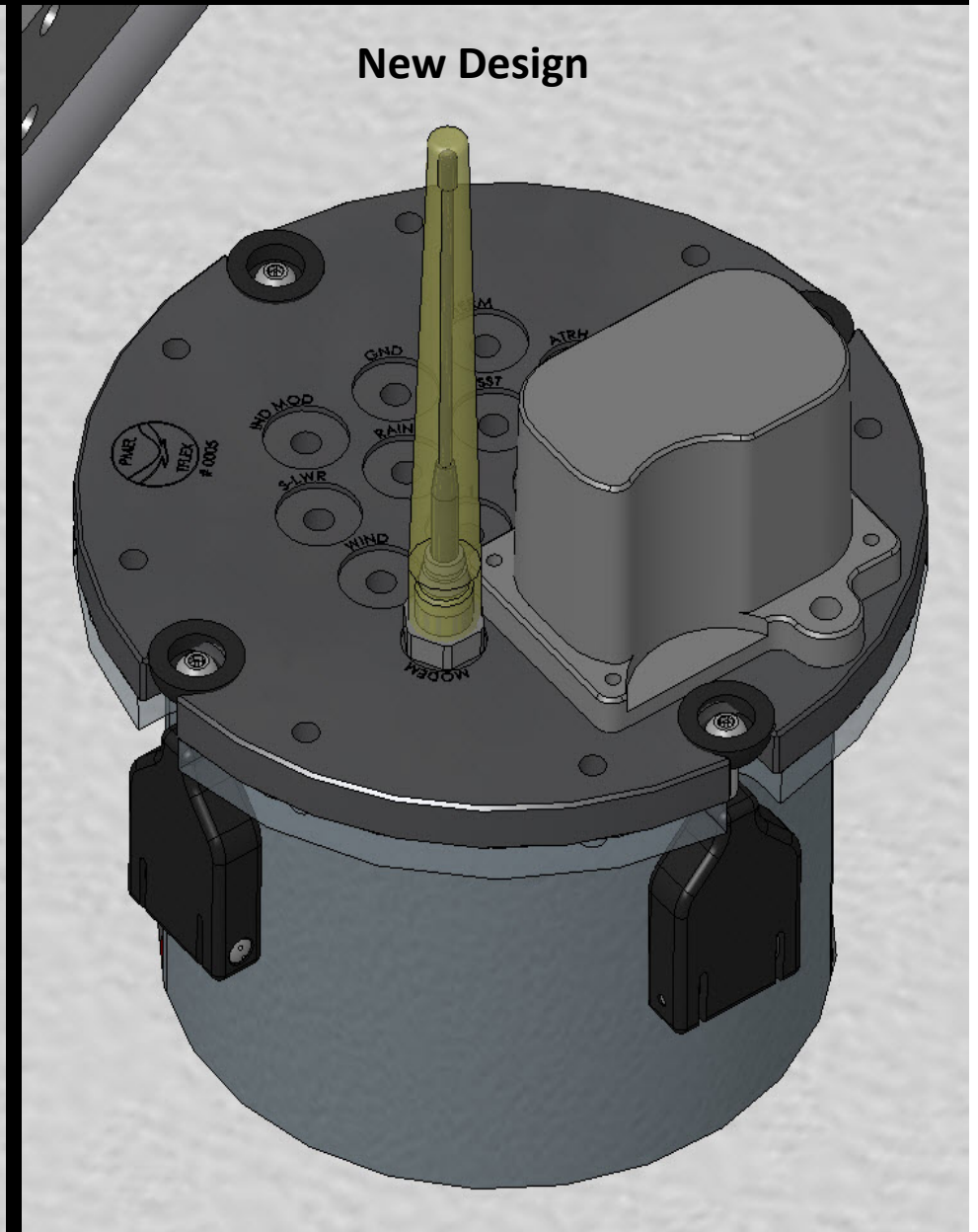
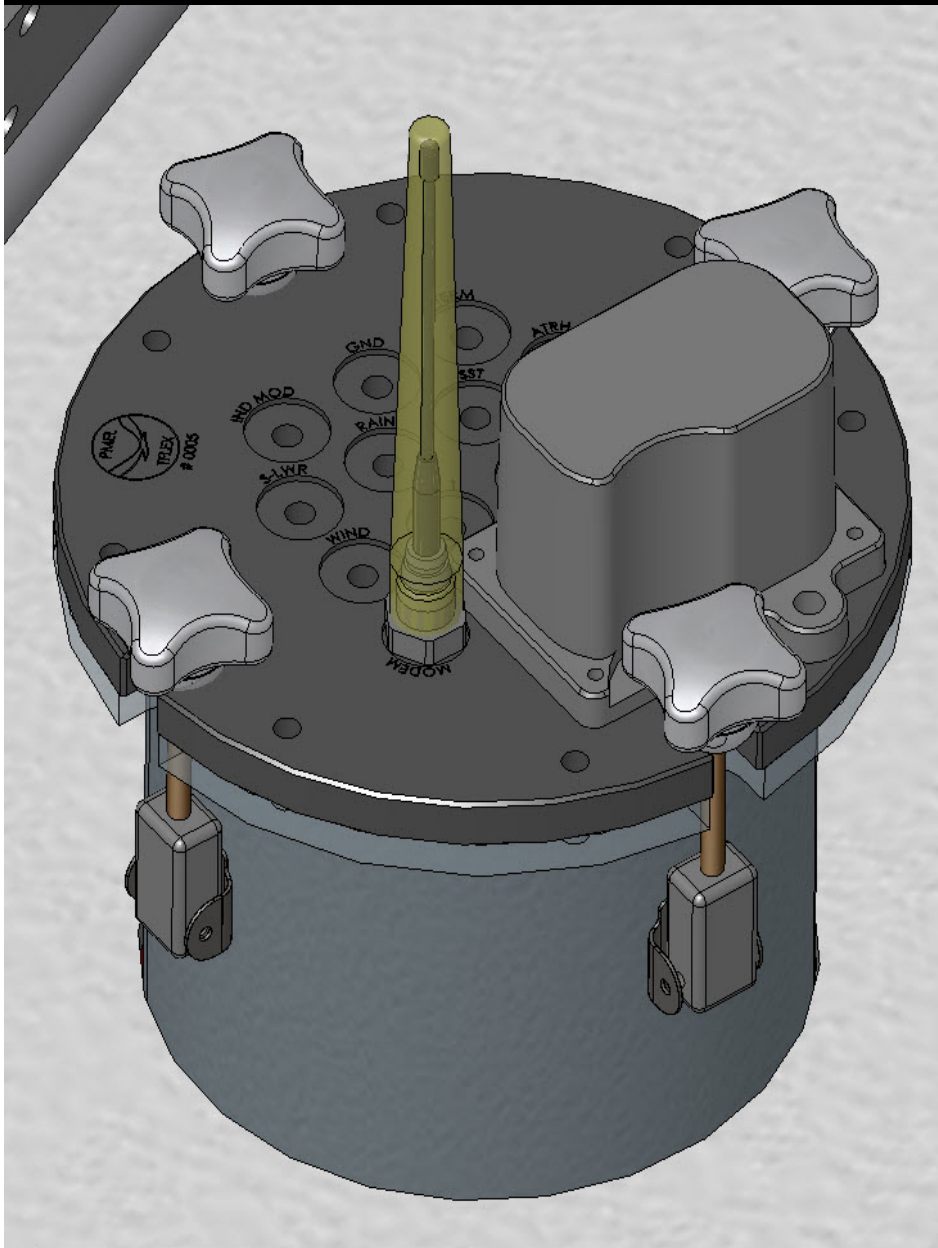

Summary:

*T-FLEX developed by following sound design
principals with tight science feedback loops*
Design completed,
prototypes built,
training personnel

Developed infrastructure

Local water tests



Questions so far?

PICO-Easy to deploy system for climate

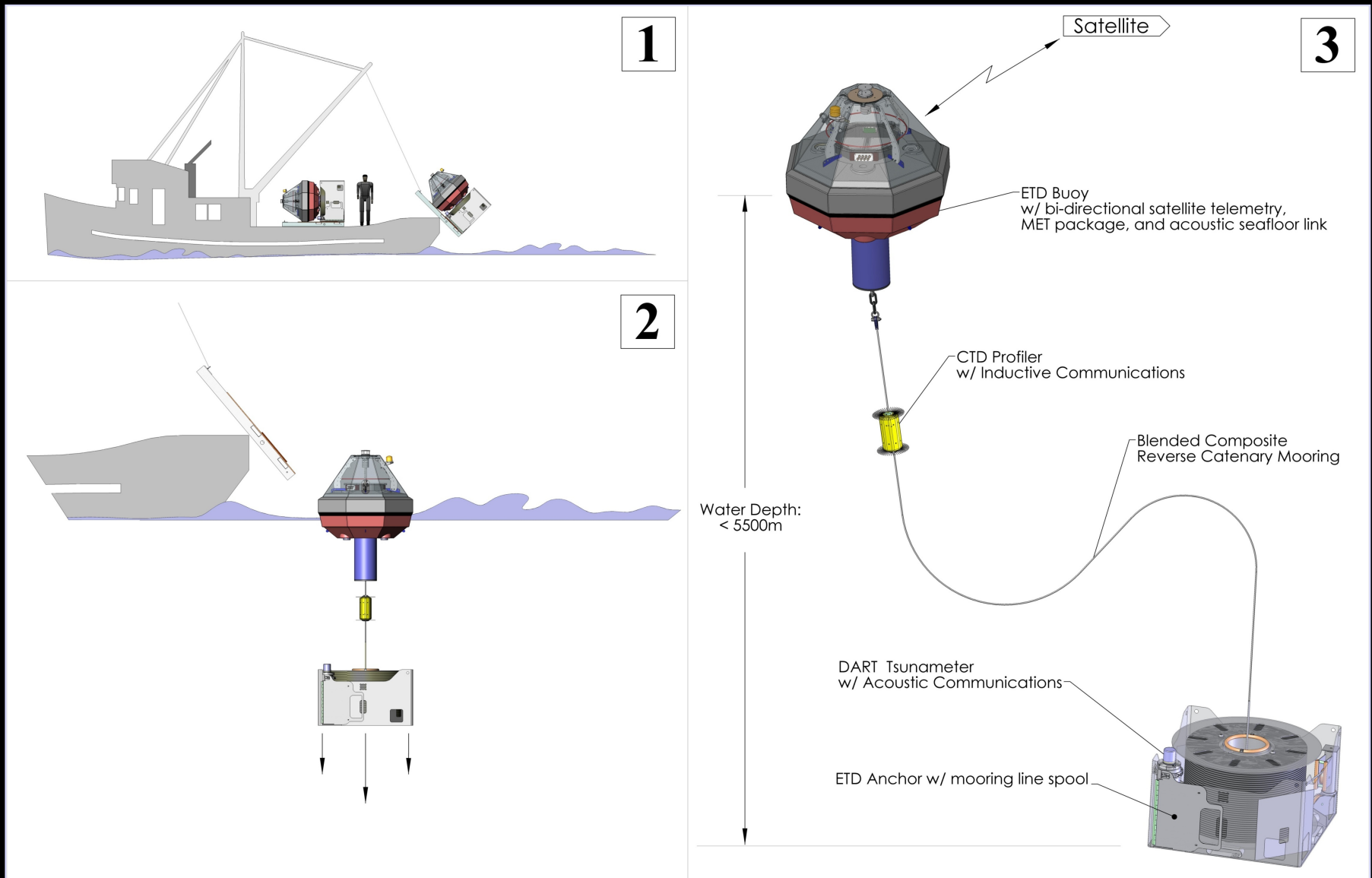

Operations & Logistics



A typical 40' container has space for only 1-2 conventional moorings but can hold up to 20 ETD systems

Profiling-Crawler ('Prawler')

Uses wave-energy of buoy mooring line to climb to top.

Command/control and data via Inductive Modem Module (IMM)

Ultra-low power pumped Seabird 'Prawler' CTD

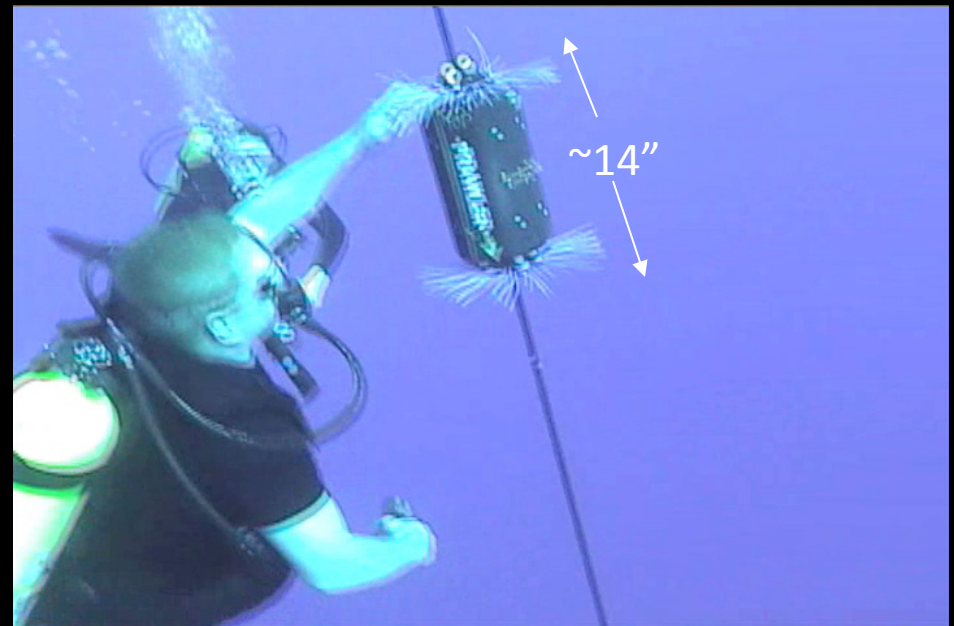

Prawler CTD

- Realtime command/control
- Choice of resolution, sample interval, top/bottom depths
- ~3500 profiles in 4 months (to date)
- ~ 1750 km profiles (to date)

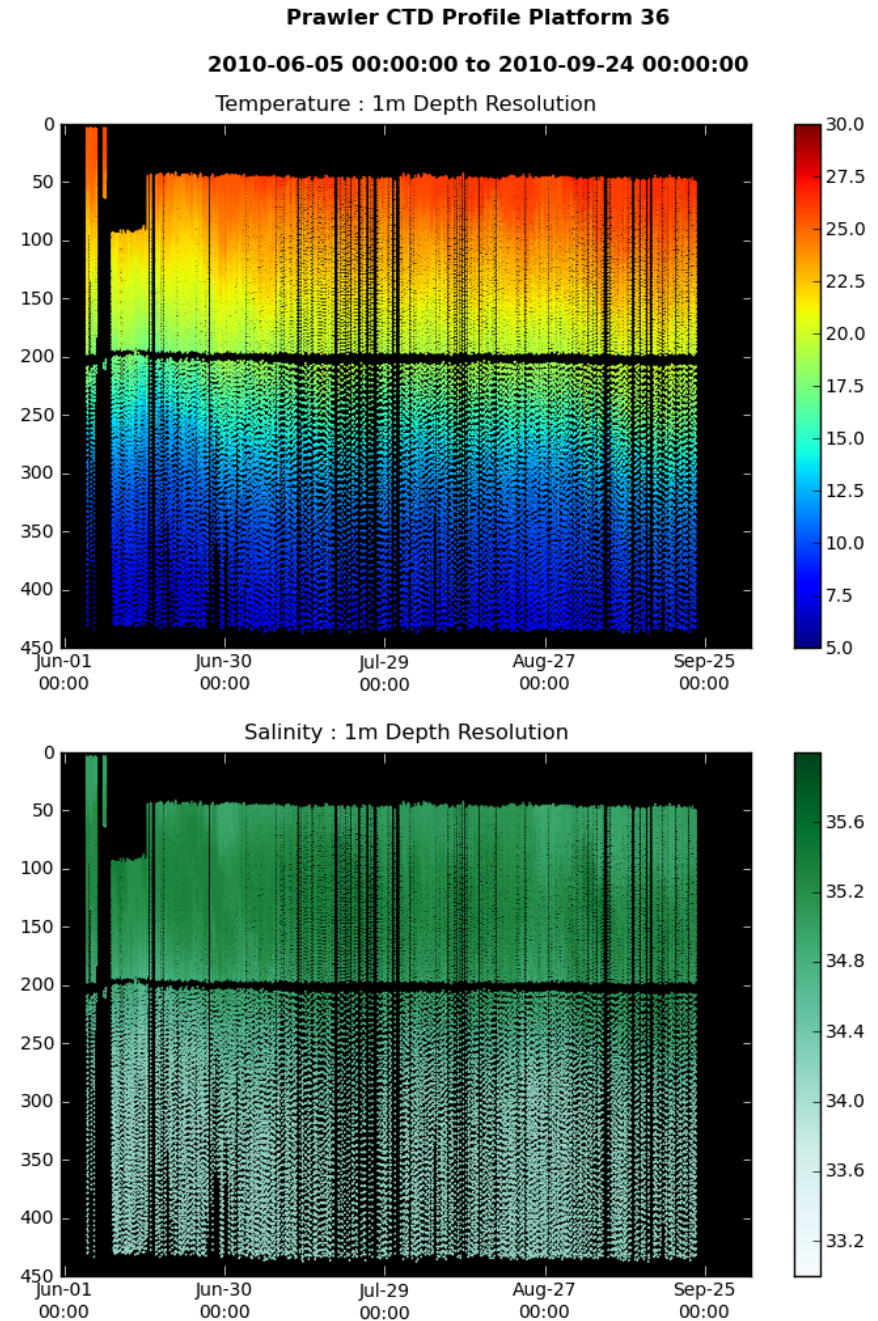

Thank You

